

(CONFIDENTIAL)

(VERTRAULICH)

Schutzvermerk ISO 16016 beachten.

The reproduction, distribution and utilization of this document as well as the communication of its contents to others without explicit authorization is prohibited. Offenders will be held liable for the payment of damages. All rights reserved in the event of the grant of a patent, utility model or design.

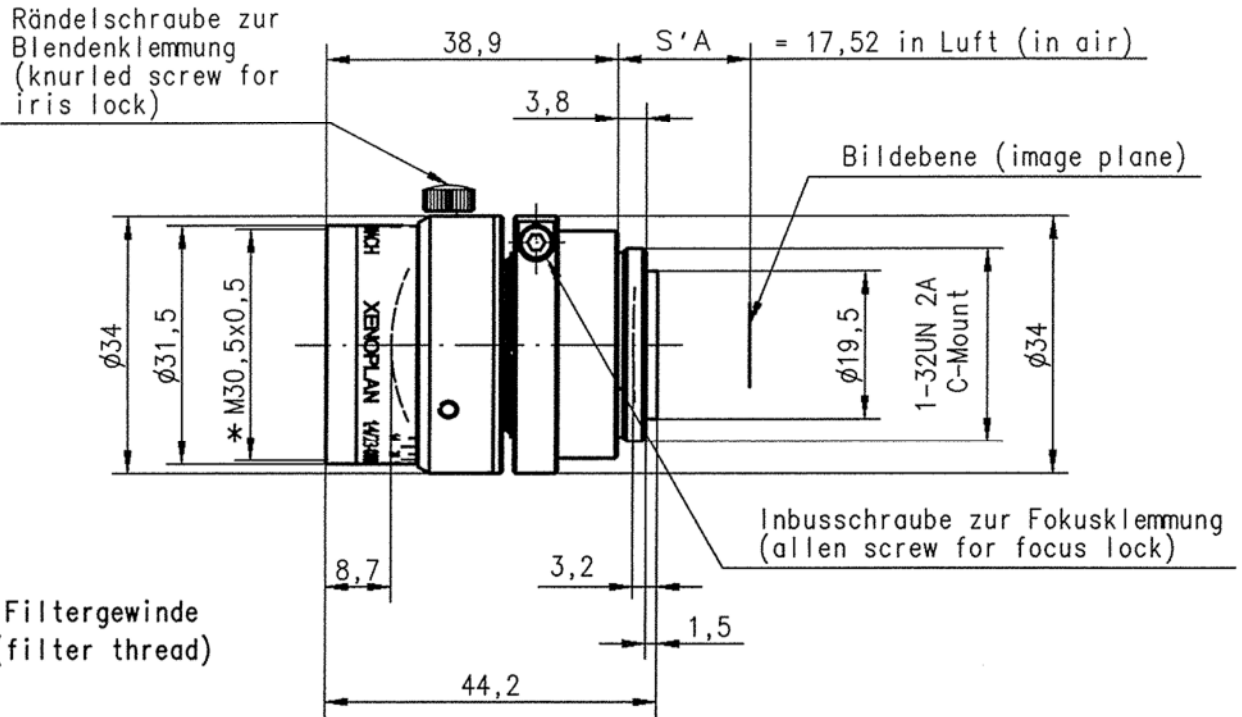

Optische Grunddaten (optical Data)

f'	22,91	s' _{AP}	-39,78	empf. Bildformat (Size of image, recommended)	6,6x8,8
s' _F	15,46	β' _p (β' = 0)	2,41	Bildkreis (Image circle)	11
s' _H	-7,45	∞' (β' = 0)	∞	Blendenbereich (Iris range)	1,4-11
HH'	-7,67	s (β' = 0)	∞	Filtergewinde (Filterthread)	M30,5x0,5
S _I S _k	32,25	s' _k (β' = 0)	15,46	Gewicht (Weight)	115g
S _{EP}	19,06	Blende (iris) φ k=1,4	9,4	Schutzkappe vorn (Front Lens Cap)	30373
Angaben ohne Einheiten in mm (all dimensions without unit in mm)				Schutzkappe hinten (Rear Lens Cap)	30422

Datum (date) 1.9.10

Nur zur Information (only for information)

Freigabe (release)		Objektiv (Lens)	Bestell-Nr. (Order-No.)
R & D	<input checked="" type="checkbox"/>	APO-XENOPLAN 1.4/23-0903	1012344
Production	<input checked="" type="checkbox"/>	APO-XENOPLAN 1.4/23-0913 RUGGEDIZED	1062875
Sales	<input checked="" type="checkbox"/>	Jos. Schneider Optische Werke GmbH Ringstr. 132 55543 Bad Kreuznach	
VT	<input type="checkbox"/>	Germany	

