

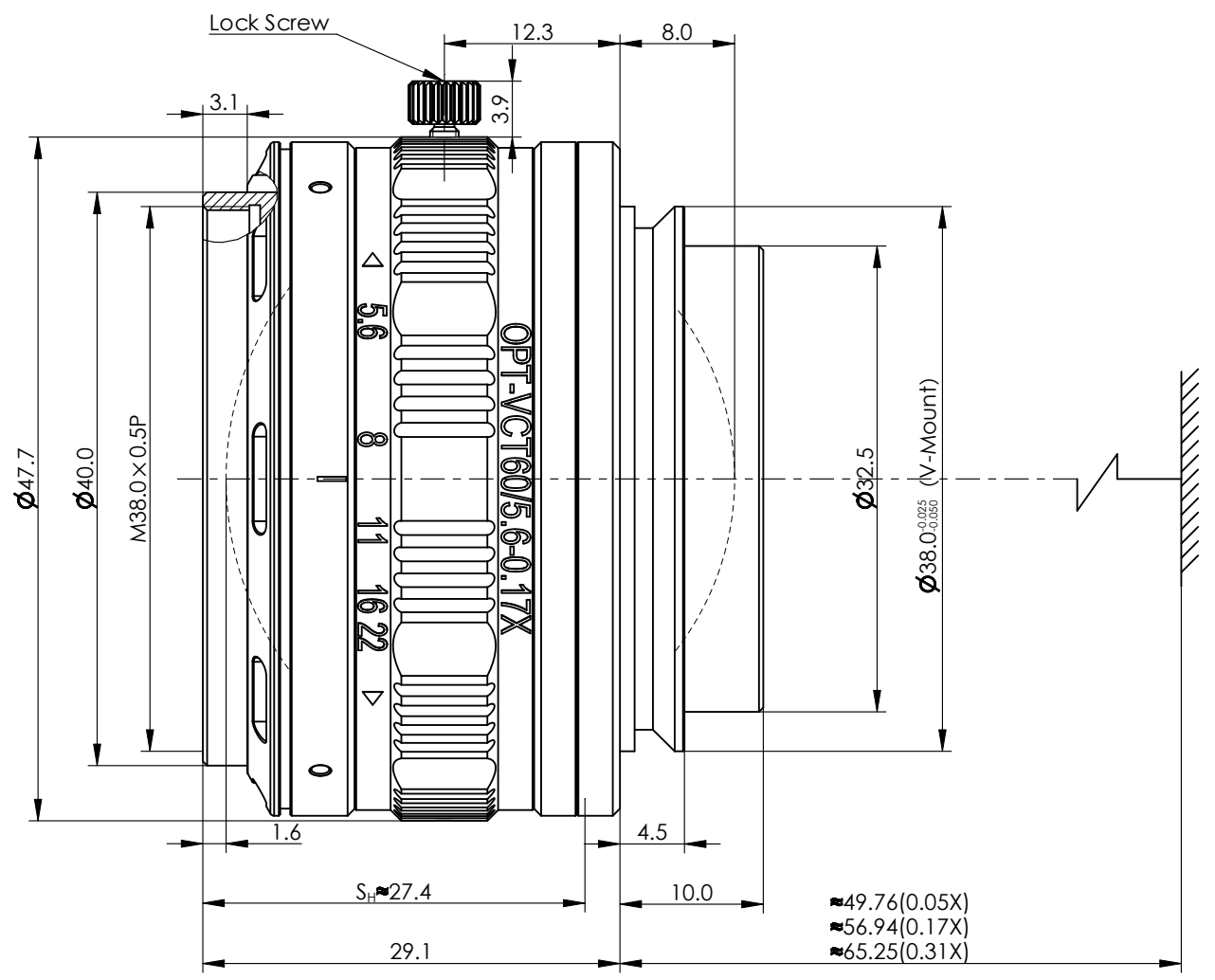

Optical Specification			
Model	OPT-VCT60/5.6-0.17X-V1.0		
Focal Length	60		
F NO.	F5.6-F22		
Image Circle	63		
Mount	V38		
Size	∅47.70×29.10		
Filter Size	M38×P0.5		
Weight	0.14Kg		
Working temperature	-20°C-60°C		
Distortion (%)	0.6	0.16	0.18
Magnification	0.05X	0.17X	0.31X
Working Distance	1232	385.5	226.2
Focal Flange Distance	49.76	56.94	65.25
O/I Distance	1313.23	476.92	322.93



View Angle	Remark	Item	Signature	Date	 OPT Machine Vision Co., Ltd.				
		Drawing				<h1>OPT-VCT60/5.6-0.17X-V1.0</h1>			
Standard Different		Design							
IT14		Check							
		Approve							
		Paper Size	A4						
Drawing Code		Revised Date	2020.07.10	Scale	2:1	Page	1/1	Version	

A

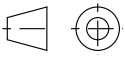
B

C

D