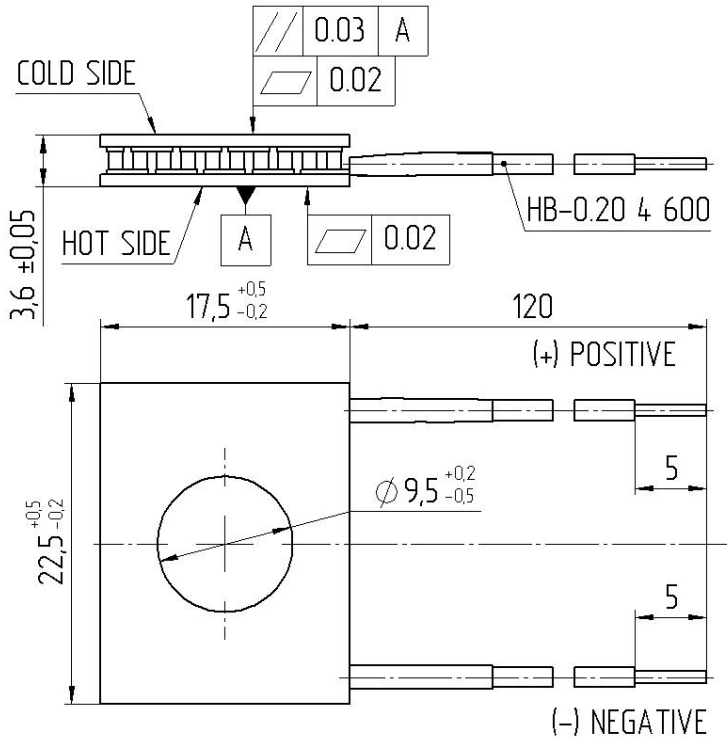
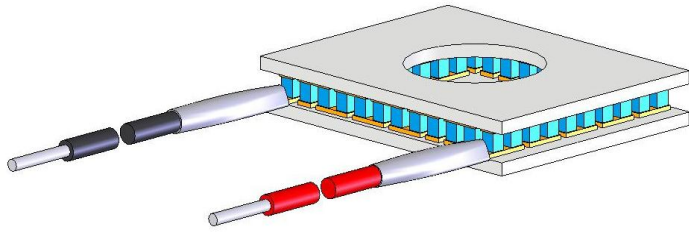

SPECIFICATION OF THERMOELECTRIC MODULE TB-41-1.0-1.3CH

Thermoelectric parameters	Unit	Value
I_{max}	Amps	3.6
U_{max}	Volts	5.1
ΔT_{max}	K	69
Q_{max}	Watts	11.2
R_{ac} (at 295 K)	Ohm	1.1
Tolerance	%	±10

All parameters except R_{ac} are given at Th=300 K

Assembly parameters	Unit	Value
Wires	HB-0.20 4 600	
Cross section	mm²	0.20
Metallization		Not
Sealing		Not
Internal solder	°C	139
Brazing solder	°C	Not

Operatiol parameters	Unit	Value
Working temperature range	°C	-50 ÷ +80
Max. processing temperature	°C	120
ROHS compliance		YES

