

**COMOSS®**

**ElectronicLinks**  
international inc



**CUSTOMER COPY**

REV.	DESCRIPTION	BY/DATE	CHECK/DATE	APPROVED/DATE
1.0	D3405	Lina Mar,24,16'		
1.1	D3721	Etta Jul,28,17'		

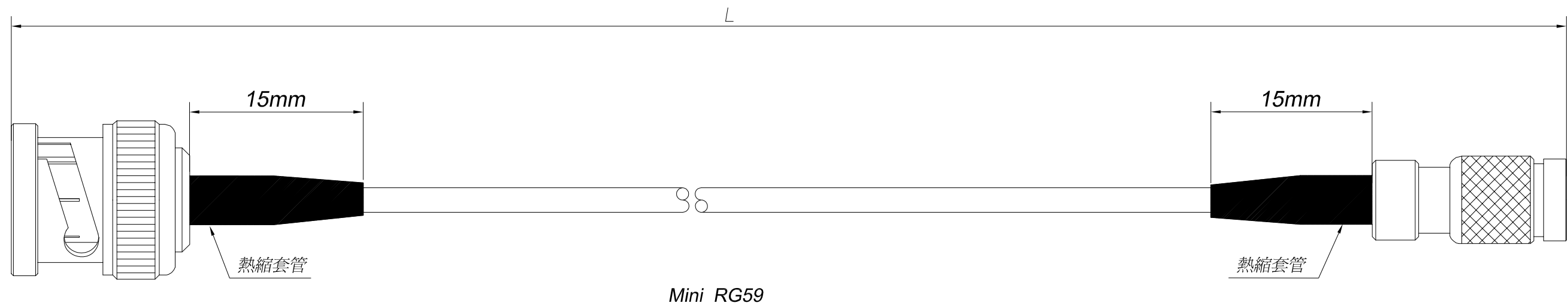

產品代號	線總長 L
B0107008	4000±50mm
B0106983	10000±100mm
B0106984	50000±100mm
B0106985	100000±150mm
B0107238	6000±50mm

Label 規格如下:

包裝:

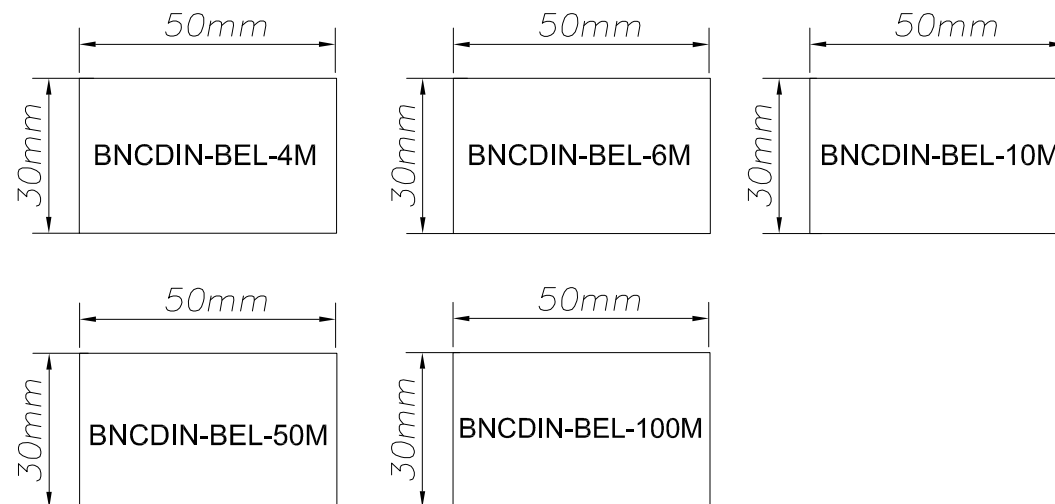
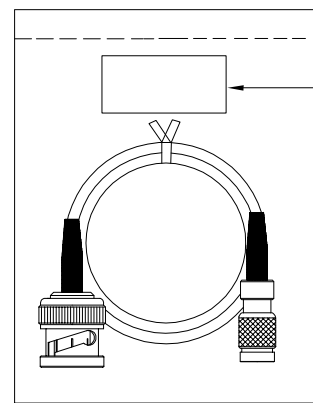

單一包裝繞圈加PE夾鏈袋.

**ElectronicLinks**  
international inc

General Tolerance .X ±0.30 .XX ±0.20 .XXX ±0.10	Angle Tolerance .X° ±1.0° .XX° ±0.5° .XXX° ±0.2°	Dwg Date <b>Etta Jul,28,17'</b>	<b>COMOSS®</b> COMOSS ELECTRONIC CO., LTD. 4F., No. 11, Chung-Hsin St., ShuLin 238, Taipei, Taiwan R.O.C.
SHEET 1/1		Design Date <b>Etta Jul,28,17'</b>	
FINISH See Notes		CHK Date	Item BNC Male-Din Male-xxM
Scale N/A	Unit: mm	APPR Date	Dwg. No. A08134
			Part No. See the table
			SIZE A4 REV 1.1

Drawing is subject to change without notice. Any updated information required, please contact with our sales dept.

## CoaXPress compare with other standard :

Standard	CoaXPress	CameraLink	GigE Vision	IEEE 1394	USB3.0
Gbit/s	1.25/3.12/6.25	2.04/5.44	1	0.8(IEEE1394b)	5
Cable no.	1	1/2(full)	1	1	1
Real time	Y	Y	N	Y	Y
Cable length (m)	170/130/50	10	100	4.5	3~5
Cable cost	L	H	L	L	L

**Order Information: xCXPx - X / 1 - X / 1 - (X)M**  
**(1) (2) (3) (4) (5) (6) (7)**

### (1) Channel : Type Description

- 1 Channel CXP
- 2 Channel CXP
- 3 Channel CXP
- 4 Channel CXP
- 5 Channel CXP

### (2) Data Speed : Type Description

- 1.25Gbps
- 3.125Gbps
- 6.25Gbps

### (3)(5) Contact Type : Type Description

- BNC
- DIN1.0/2.3

### (4)(6) Overmold Type : Type Description

- Straight or Angled type

### (7) Cable Length : by meter



**ElectronicLinks**  
 international inc

As a professional Machine Vision cable solution provider, COMOSS CoaXPress (CXP) cable has been certified by JIIA in 2017. More information, please contact our regional sales or email [sales@comoss.com.tw](mailto:sales@comoss.com.tw)

# Certificate

Name and address of the applicant  
Comoss Electronic Co., Ltd.

Model name of Product or Application  
CoaXPress cable Seriesx CXP6-x/1-x/1-(20)M

Rating and principal characteristics  
Cable

Test Condition  
JIIA CXPR-001-2011 Electrical Compliance Test Specification for JIIA  
CoaXPress Standard (2011-10-28)

Test date 2017/12/04 Report No, CXP-ECTR-2017120408

Test date \_\_\_\_\_ Report No, \_\_\_\_\_

GenICam GenTL Interoperability Test N/A

Date Feb. 22, 2018

Certification Body : Japan Industrial Imaging Association

  
Sachio Kiura / Chairman