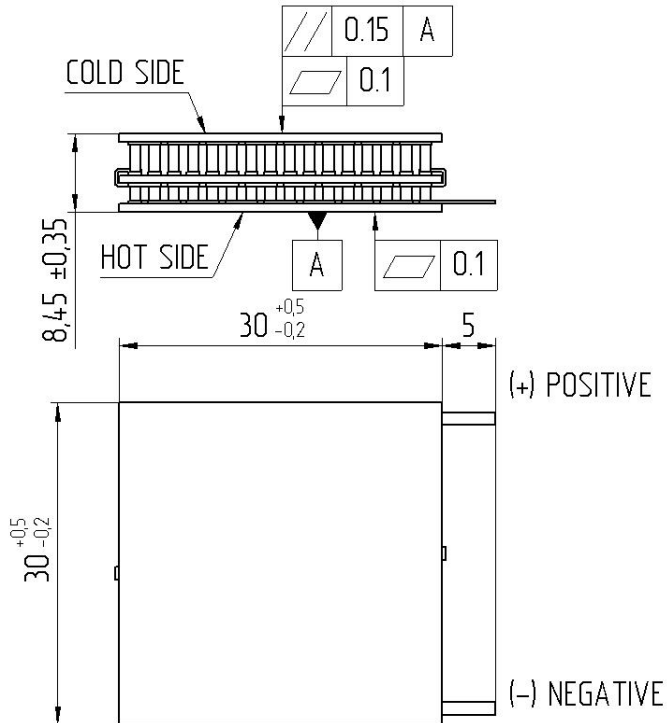
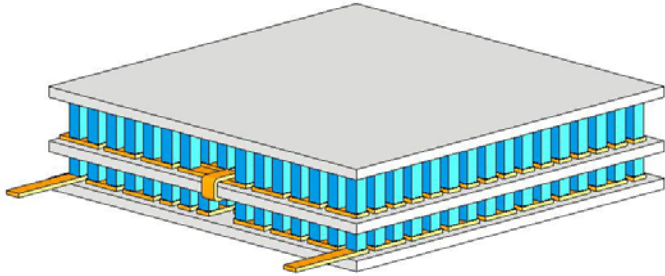

SPECIFICATION OF THERMOELECTRIC MODULE TB-2-(127-127)-1.3

Thermoelectrical parameters	Unit	Value
I_{max}	Amps	2.8
U_{max}	Volts	15.4
ΔT_{max}	K	83
Q_{max}	Watts	16.1
Tolerance	%	±10

All parameters except R_{ac} are given at Th=300 K

Assembly parameters	Unit	Value
Wires	-	-
Cross section	mm²	-
Metallization	-	Not
Sealing	-	Not
Internal solder	°C	139
Brazing solder	°C	not

Operational parameters	Unit	Value
Working temperature range	°C	-50 ÷ +80
Max. processing temperature	°C	130
ROHS compliance	-	YES

