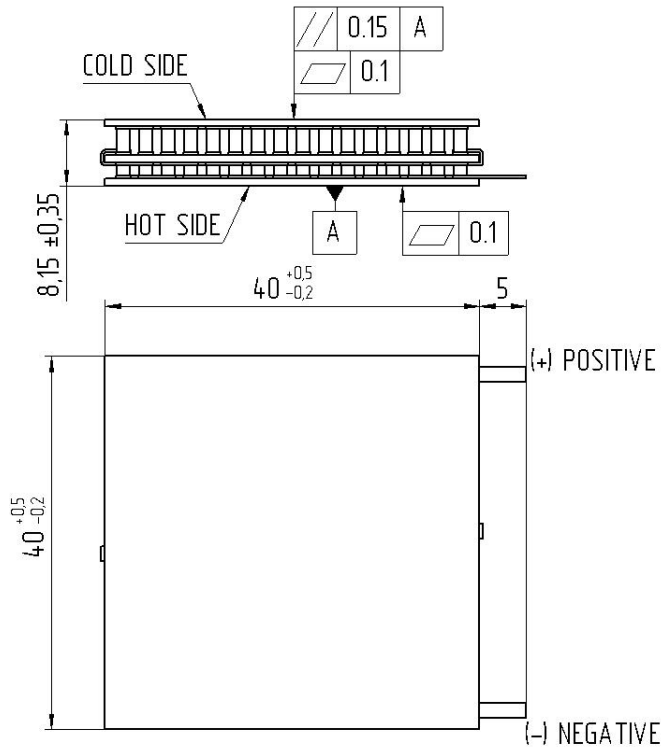
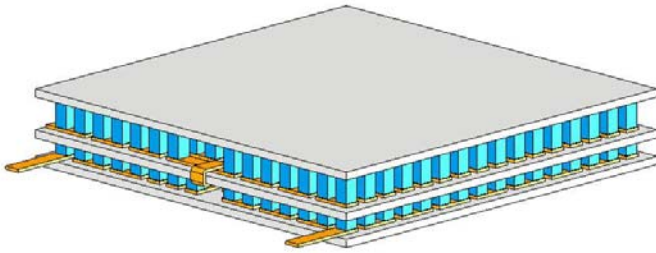

SPECIFICATION OF THERMOELECTRIC MODULE TB-2-(127-127)-1.15

Thermoelectrical parameters	Unit	Value
I_{max}	Amps	10.2
U_{max}	Volts	24
ΔT_{max}	K	84
Q_{max}	Watts	95
Tolerance	%	±10

All parameters except R_{ac} are given at Th=300 K

Assembly parameters	Unit	Value
Wires		-
Cross section	mm²	-
Metallization		Not
Sealing		Not
Internal solder	°C	139
Brazing solder	°C	not

Operational parameters	Unit	Value
Working temperature range	°C	-50 ÷ +80
Max. processing temperature	°C	130
ROHS compliance		YES

