



For Surveillance Telephoto Zoom

Applicable camera (model)

1	2/3	1/2	1/3	1/4
---	-----	-----	-----	-----

22x



*Photograph is a similar model.

- High-power zoom lens with focal length of 500mm, best suited for remote surveillance.
- Compact and lightweight design, allowing compact systems to be easily established.
- Multi power compatibility (6V, ±6V, 12V, ±12V), for use with existing control systems.
- Special built-in ND filter of T3000, providing support for ultra sensitive cameras.
- Auto iris is remotely operable, allowing light intensity to be fine adjusted according to the monitoring target.
- Supports 1" II tube cameras.

ZOOM
Zoom

TELE
Telephoto
Long Focal

MOTOR DRIVE
Motor Drive

VIDEO
Video Auto Iris

IRIS-REMOTE
Iris Remote

C-mt
C Mount

METAL
Metal Mount

PRESET
Potentiometer

ND
ND Filter

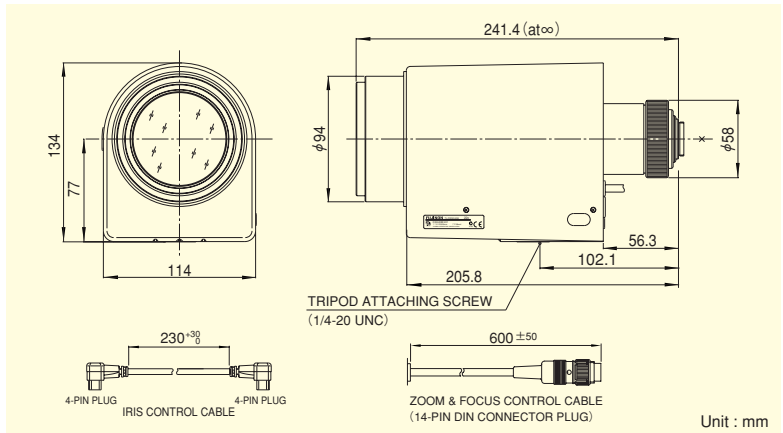

Focal Length (mm)		23~506 (22x)	
Iris Range		F3.1 ~ T3000 (Equivalent to F3000)	
Operation	Zoom	Motor Drive	
	Focus	Motor Drive	
	Iris	Auto (Video Type) or Remote (*1)	
Angle Of View (HxV)	1"	WIDE	31°06' × 23°35'
		TELE	1°27' × 1°05'
	2/3"	WIDE	21°40' × 16°20'
		TELE	1°00' × 0°45'
	1/2"	WIDE	15°50' × 11°55'
		TELE	0°43' × 0°33'
	1/3"	WIDE	11°55' × 8°57'
		TELE	0°32' × 0°24'
Focusing Range (From Front Of The Lens) (m)		∞ ~ 3	
Object Dimensions at M.O.D. (HxV) (mm)	1"	WIDE	1611 × 1208
		TELE	73 × 55
	2/3"	WIDE	1108 × 831
		TELE	50 × 38
	1/2"	WIDE	806 × 604
		TELE	37 × 27
	1/3"	WIDE	604 × 453
		TELE	27 × 21
Back Focal Distance (in air) (mm)		39.54	
Exit Pupil Position (From Image Plane) (mm)		-64	
Filter Thread (mm)		M82 × 0.75	
Mount		C	
Mass (kg)		2.4	
Standard Accessories		Iris Control Cable	
Remarks		• With Metal Mount (*1) For Iris remote function please refer to page (J-1)	

Wiring

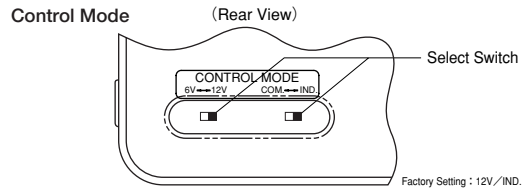
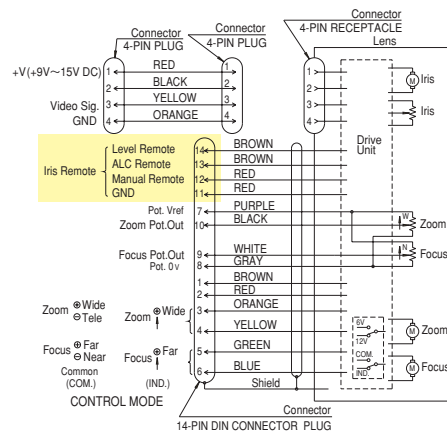

Controller output	Select switch position
6V	6V / IND.
±6V	6V / COM.
12V	12V / IND.
±12V	12V / COM.

Accessories

Extender Model	Magnification
HE15-1	1.5x
HE20-1	2x